

'Hot Rod' Jig

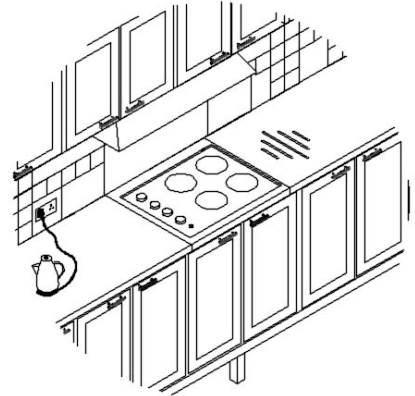
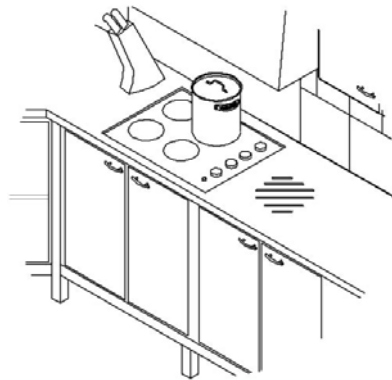
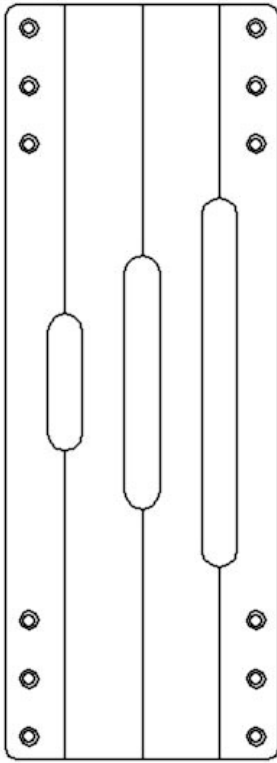

The 'Hot Rod' jig is designed and manufactured by one of Europe's leading routing jig manufactures and will enable you to rout grooves in most worktop or counter tops to receive Stainless Steel 'Hot Rods'.

- ◆ The jig features three purpose made grooves which will produce recesses for 300mm, 200mm and 100mm long 'Hot Rods'.
- ◆ Additional features include three sets of peg holes allowing you to accurately position the jig so that the grooves run at 90° to the worktop edges. These are at 20mm, 70mm and 120mm intervals.

Pack Contents include:-

- ◆ One Jig Plate
- ◆ Instructions
- ◆ Two black pegs

Additional equipment required:-

- ◆ An electric hand held router
- ◆ Two 'Quick Off' or 'G' Clamps
- ◆ 6.3mm radius (Ø12.7mm) Tungsten Carbide Ball nosed Cutter
- ◆ Adhesive
- ◆ 30mm Router Guide Bush

HEALTH AND SAFETY

1. Always ensure the worktop is supported properly.
2. Always ensure that the path of the router is clear of any obstacles.
3. Always ensure that the cable of the router is clear of the jig and is of sufficient length.
4. Always wear protective goggles when cutting.
5. Do not switch router on with the cutter touching the work piece.
6. Read the routers instruction manual if there are any doubts on the correct operation.

DURING CUTTING

1. Never try to cut more than 10mm depth on one cut.
2. Do not force the router too fast. This can damage expensive router bits.
3. Never, never remove the router from the jig whilst it is in motion. Always allow router to stop and switch off before removing.

If routing for a long period of time, we advise that ear protection is worn.

Before starting

Use a 6.3mm radius or 12.7mm Diameter Round or Radius Cutter.

The Hot Rods are 12mm in diameter and generally it is desirable to recess the rods into the worktop by approximately one third to one half of their diameter.

Set the depth of your router to 5 - 6mm and test the depth of the router on a spare piece of material first and fit the Hot Rods to see if this is how you want your worktop with Hot rods to look.

Choose the location and your preferred orientation of your Hot Rods.

You can either utilise the pegs provided to locate the jig at a set distance from the worktop or countertop edge - as shown in figure 1.

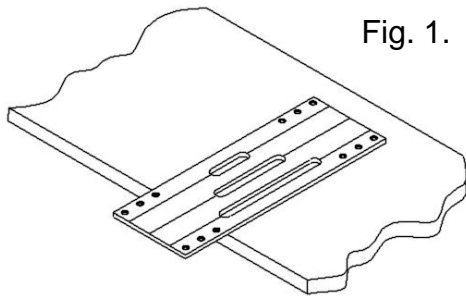

Or use your imagination and place it in the position that you feel will look best.

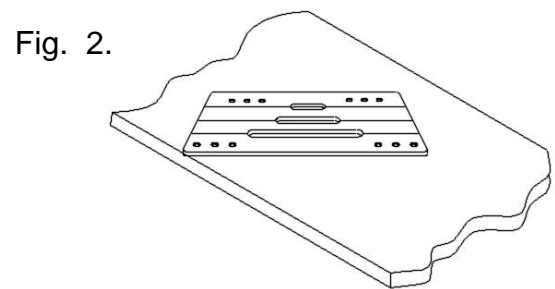

Once the position is decided, clamp the jig very securely to the worktop.

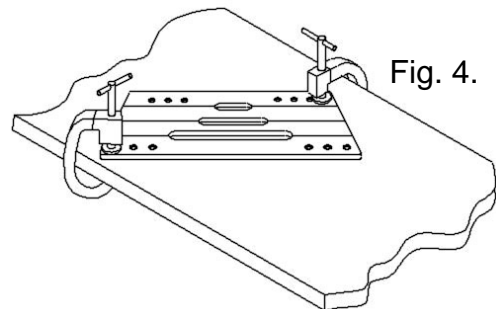
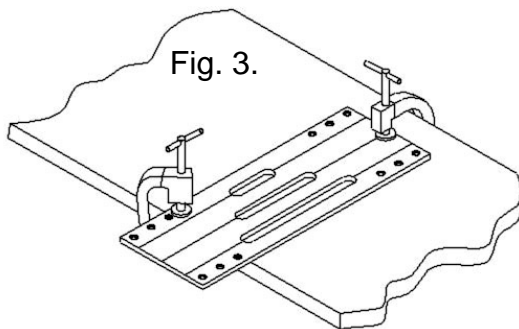

The Hot Rods are 12mm in diameter and generally it is desirable to recess the rods into the worktop by approximately one third to one half of their diameter.

Make a single straight pass for each groove.

Fix the Stainless Steel Hot Rods into place using a suitable adhesive. Always refer to the manufacturers instruction before and during use.

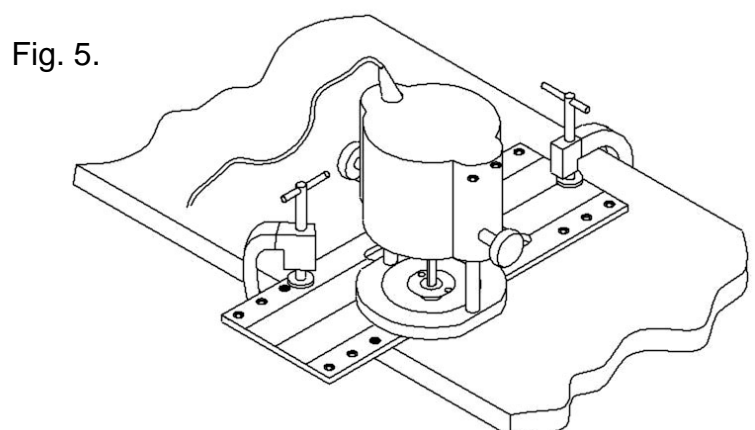

If you wish to rout further grooves , for example, in a mirror image of the first grooves you have routed, simply flip the jig over and line up the edge of the jig with the edge of a routed groove as shown in figure 6.

Ensure the jig is lined up at an equal distance from the edge of the worktop as the previous operation. Simply re-clip and rout..

Fig. 6.

